



RATCHET WRENCHES

1/4" DRIVE Standard Duty

RW250B (400005)

- Compact lightweight design allows work in confined spaces
- Very fast 240 R.P.M. head accomplishes nut running far quicker than by hand
- Reaches areas air impacts can't
- Ball type socket retainer allows quick socket changes
- Ideal for running small fasteners and light duty general repair work
- **MAXIMUM TORQUE: 18 FT - LBS**



18 FT - LBS

1/4" DRIVE "MINI" Heavy Duty

RW25HDM (400007)

- Our most powerful & compact 1/4 "mini" ratchet
- Slim profile head ideal for engine compartment & under-dash work
- Contoured composite housing cover with traction pad for maximum operator comfort and control
- Fully recessed throttle for easy grip
- Longer service life provided by roll forged pawl to limit spreading and special heat treating and precision machining of all components
- A professional tool for the professional user
- **MAXIMUM TORQUE: 25 FT - LBS**



NEW!

6-3/4"

Check & Compare!
25 FT - LBS

3/8" DRIVE "MINI" Standard Duty

RW375M (400152)

- This "mini" ratchet wrench allows work in tight spaces where standard ratchet wrenches can't fit
- Ball type socket retainer allows quick socket changes
- Intake screen protects motor for extended life
- An excellent addition to any shop for running small fasteners
- **MAXIMUM TORQUE: 15 FT - LBS**



15 FT - LBS

3/8" DRIVE "MINI" Heavy Duty

RW38HDM (400113)

- Same great features as RW25HDM in a 3/8 "mini" ratchet
- **MAXIMUM TORQUE: 25 FT - LBS**



NEW!

6-3/4"

Check & Compare!
25 FT - LBS

JET Accessories



3/8" DRIVE POWER SOCKETS

Featuring Torque-Drive™ power socket design.
Please consult our hand-tool catalogue for range and specifications.

MOD. NO. PROD. NO.	RW250B 400005	RW25HDM 400007	RW375M 400152	RW38HDM 400113
Square Drive	1/4"	1/4"	3/8"	3/8"
Max. Torque by Hand (Ft.- Lbs.)	—	70	—	70
Working Torque (Ft. - Lbs.)	18	25	15	25
Free Speed R.P.M.	240	250	250	250
Standard Bolt Capacity	5/16"	3/8"	5/16"	3/8"
Overall Length	8-3/4"	6-3/4"	7-1/2"	6-3/4"
Weight (Lbs.)	1.10	1.15	1.18	1.15
Avg. Air Consumption (CFM)	3	2.55	2.5	2.55
Min. Hose Size	5/16"	3/8"	1/4"	3/8"
Air Inlet NPT	1/4"	1/4"	1/4"	1/4"
Sound Pressure (dBA)	—	89.1	—	89.1
Vibration (M/S ²)	—	2.32	—	2.32

• FOR MAXIMUM PERFORMANCE WE RECOMMEND 90 LB PSI AIR PRESSURE

RATCHET WRENCHES



3/8" DRIVE Standard Duty RW375X (400108)

- JET's most popular air ratchet
- Improved ratchet head assembly and motor design results in powerful torque output
- Fast 150 R.P.M. head
- Ball type socket retainer allows quick socket changes
- Intake screen protects motor for extended life
- Ideal for a variety of automotive applications including exhaust system, water and fuel pump work, air conditioner, radiator and spark plug removal/replacement and general engine and body shop work
- **MAXIMUM TORQUE: 50 FT - LBS**



50 FT - LBS

3/8" DRIVE Heavy Duty RW375HD (400109)

- This professional quality, heavy duty ratchet wrench features a high performance five blade motor, producing 70 ft/lbs of torque. It is our most powerful ratchet wrench
- 360° swivel air inlet prevents twists in the hose for improved tool handling
- Ergonomic handle, with insulating and vibration absorbing rubber cover, for operator comfort and control
- Fully recessed throttle for easy grip
- Air outlet swivels 360° allowing exhaust to be directed away from the operator
- Slim, low profile ratchet head & long neck design permits better access in tight work areas
- Longer service life provided by roll forged pawl to limit spreading and special heat treating and precision machining of all components
- **MAXIMUM TORQUE: 70 FT - LBS**



70 FT - LBS

1/2" DRIVE Standard Duty RW500X (400213)

- Same high quality features as model RW375X except the anvil is 1/2" drive
- **MAXIMUM TORQUE: 50 FT - LBS**



50 FT - LBS

1/2" DRIVE Heavy Duty RW500HD (400214)

- Same high quality features as model RW375HD except the anvil is 1/2" drive
- **MAXIMUM TORQUE: 70 FT - LBS**



70 FT - LBS

MOD. NO. PROD. NO.	RW375X 400108	RW375HD 400109	RW500X 400213	RW500HD 400214
Square Drive	3/8"	3/8"	1/2"	1/2"
Max. Torque by Hand (Ft. - Lbs.)	—	120	—	120
Working Torque (Ft. - Lbs.)	50	70	50	70
Free Speed R.P.M.	150	160	150	160
Standard Bolt Capacity	3/8"	3/8"	3/8"	3/8"
Overall Length	10-1/4"	11-3/4"	10-1/4"	11-3/4"
Weight (Lbs.)	2.46	2.8	2.46	2.8
Avg. Air Consumption (CFM)	4	2.6	4	2.6
Min. Hose Size	3/8"	3/8"	3/8"	3/8"
Air Inlet NPT	1/4"	1/4"	1/4"	1/4"
Sound Pressure (dBA)	—	90.8	—	90.8
Vibration (M/S ²)	—	1.93	—	1.93

- **FOR MAXIMUM PERFORMANCE WE RECOMMEND 90 LB PSI AIR PRESSURE**

JET Accessories



3/8" DRIVE DEEP POWER SOCKETS

Featuring Torque-Drive™ power socket design. Please consult our hand-tool catalogue for range and specifications.



100 FT - LBS



200 FT - LBS

JET Accessories



3/8" DRIVE POWER SOCKETS

Featuring Torque-Drive™ power socket design.
Please consult our hand-tool catalogue for range and specifications.

IMPACT WRENCHES

**3/8" DRIVE Standard Duty
AW375PX (400104)**

- Lightweight, compact design ensures maximum operator comfort
- Built-in power regulator
- Convenient forward/reverse switch allows quick direction changes
- Comfortable trigger switch
- Rubber nose-piece protects housing
- Intake screen protects motor for extended life
- Ideal for general automotive work up to 3/8" bolt size, including transmission and exhaust system work
- **MAXIMUM TORQUE: 100 FT - LBS**

**3/8" DRIVE MAGNESIUM SERIES Heavy Duty
AW375MHD (400110)**

- Pin clutch impact mechanism provides high torque, fast run down and minimum vibration
- Super strong magnesium housing - lighter and stronger than aluminum, magnesium absorbs impact vibration better than other materials, improving operator comfort and reducing fatigue
- Exceptionally well balance tool for comfort and ease of handling
- Ergonomic handle shaped to fit the operator's hand features: finger grooves for comfort and control; insulating and shock absorbing rubber cover extends to upper rear of handle to protect the web of the hand
- Exhaust air outlet features an effective muffler system for reduced noise in the work area
- Handle exhaust directs air away from the operator and the work piece
- Forward/reverse control positioned for ease of use, three forward and one reverse settings
- Specially treated anvil for maximum service life
- A professional tool for professional users. Ideal for all automotive, industrial and farm service applications using up to 1/2" fasteners
- **MAXIMUM TORQUE: 200 FT - LBS**

MOD. NO.	AW375PX	AW375MHD
PROD. NO.	400104	400110

Square Drive	3/8"	3/8"
Max. Torque (Ft. - Lbs.)	100	200
Working Torque (Ft. - Lbs.)	60 - 70	170
Free Speed R.P.M.	10,000	10,000
Standard Bolt Capacity	3/8"	1/2"
Overall Length	5-1/4"	6-1/4"
Weight (Lbs.)	2.5	2.6
Avg. Air Consumption (CFM)	3	2.5
Min. Hose Size	3/8"	3/8"
Air Inlet NPT	1/4"	1/4"
Sound Pressure (dBA)	-	106
Vibration (M/S ²)	-	1.17

• FOR MAXIMUM PERFORMANCE WE RECOMMEND 90 LB PSI AIR PRESSURE

IMPACT WRENCHES



3/8" DRIVE BUTTERFLY Standard Duty AW375B (400105)

- Compact design permits use in confined spaces
- "Butterfly" style throttle allows instant, single hand direction changes and speed control
- 8 positive throttle settings for pre-set operating speeds
- Swivel mounted air inlet for easy access to tight spaces
- Rubber nose guard protects the front housing from damage
- Anvil features a snap ring socket retainer
- Motor components are hardened for longer service life
- Air inlet screen for extended motor life
- **MAXIMUM TORQUE: 75 FT - LBS**

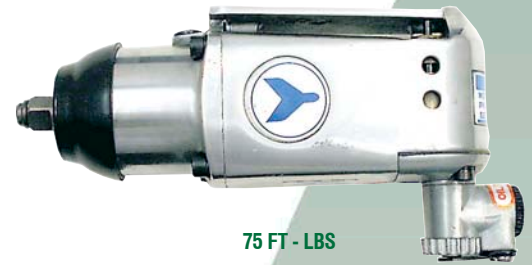

75 FT - LBS

3/8" DRIVE BUTTERFLY Heavy Duty AW38BHD (400116)

- Industry's hardest hitting butterfly wrench - 85 foot pounds of maximum torque in the palm of your hand!
- All this power from an amazingly compact, ergonomic tool - only 5-7/8" long!
- Small diameter hammer casing tapers at the nose for improved access in hard-to-reach areas
- "Butterfly" style throttle allows instant, single hand direction changes and speed control
- 18 positive throttle settings for pre-set operating speeds
- Heavy duty swivel mounted air inlet for easy access to tight places
- Grease port on hammer casing for easy lubrication & longer service life
- Ideal for working on small fasteners in tight work spaces, a professional tool for professional users.
- **MAXIMUM TORQUE: 85 FT - LBS**



NEW!

5-7/8"
Check & Compare!
85 FT - LBS

1/2" DRIVE Economy AW550XPV (400234)

- 6 vane air motor delivers up to 230 ft-lbs of torque
- Convenient forward/reverse switch enables quick directional changes
- Built-in power regulator
- Vinyl cover protects housing
- Intake screen protects motor for extended life
- This economical 1/2" impact wrench offers good performance for automotive uses such as brake, tire, exhaust and body work
- Replacement vinyl cover (Prod. No. 905117)
- **MAXIMUM TORQUE: 230 FT - LBS**



230 FT - LBS

MOD. NO. PROD. NO.	AW375B 400105	AW38BHD 400116	AW550XPV 400234
Square Drive	3/8"	3/8"	1/2"
Max. Torque (Ft. - Lbs.)	75	85	230
Working Torque (Ft. - Lbs.)	10 - 65	10 - 60	50 - 200
Free Speed R.P.M.	10,000	11,000	7,000
Standard Bolt Capacity	3/8"	3/8"	1/2"
Overall Length	6-1/4"	5-7/8"	7"
Weight (Lbs.)	2.5	1.8	5.1
Avg. Air Consumption (CFM)	3	2.2	4
Min. Hose Size	3/8"	3/8"	3/8"
Air Inlet NPT	1/4"	1/4"	1/4"
Sound Pressure (dBA)	-	97.3	—
Vibration (M/S ²)	-	6.92	—

- **FOR MAXIMUM PERFORMANCE WE RECOMMEND 90 LB PSI AIR PRESSURE**

JET Accessories



JET carries a full line of heavy duty 3/8", 1/2", 3/4" and 1" drive impact sockets. Please consult our hand tool catalogue for range and specifications.

IMPACT WRENCHES



1/2" DRIVE MAGNESIUM SERIES Super Duty AW500MSD (400245)

- Twin hammer impact mechanism provides more power and smooth, balanced impact blows for reduced vibration
- Super strong magnesium housing - lighter and stronger than aluminum, magnesium absorbs impact vibration better than other materials, improving operator comfort and reducing fatigue
- Exceptionally well balanced tool, for comfort and ease of handling
- Ergonomic handle shaped to fit the operator's hand features: finger grooves for comfort and control; insulating and shock absorbing rubber cover extends to upper rear of handle to protect the web of the hand
- Exhaust air outlet features an effective muffler system for reduced noise in the work area
- Handle exhaust directs air away from the operator and the work piece
- Forward/Reverse control positioned for ease of use, three forward and one reverse setting
- Maximum power in reverse for removing those stubborn fasteners
- Specially treated anvil for extra long service life
- A professional tool for professional users. Ideal for all automotive, industrial and farm service applications including truck, shock, frame, engine & spring work
- **MAXIMUM TORQUE: Forward 550 FT-LBS, Reverse 600 FT-LBS**



600 FT-LBS

1/2" DRIVE MAGNESIUM SERIES Super Duty AW500MSDE (400246) (2" Extended Anvil)

- Same great MAGNESIUM SERIES features in a 2" extended anvil version
- **MAXIMUM TORQUE: Forward 550 FT-LBS, Reverse 600 FT-LBS**



NEW!
600 FT-LBS

1/2" DRIVE COMPOSITE SERIES Super Duty AW500CSD (400247)

- Super strong and super light weight, featuring the latest in composite technology, AW500CSD delivers 700 FT/LBS of nut wrenching power in an incredibly light, 4.5 lb package
- Our most powerful 1/2" impact wrench
- Twin hammer impact mechanism provides more power and smooth, balanced impact blows for reduced vibrations
- Unique "Up-Hill Soft-Grip" design makes this tool ideal for long hours on the job
- Muffled, handle mounted air outlet adds to operator comfort and safety
- "Dial type" Forward/Reverse control positioned for ease of use, three forward and one reverse setting
- Maximum power in reverse for removing those stubborn fasteners
- Specially treated anvil for long service life
- A professional tool for professional users. Ideal for all automotive, industrial & farm service applications including truck, shock, frame & spring work
- **MAXIMUM TORQUE: Forward 650 FT - LBS, Reverse 700 FT - LBS**



NEW!
700 FT-LBS

**SUPER STRONG
SUPER LIGHT** COMPOSITE
HOUSING

MOD. NO. PROD. NO.	AW500MSD 400245	AW500MSDE 400246	AW500CSD 400247
Square Drive	1/2"	1/2"	1/2"
Max. Torque (Ft. - Lbs.)			
Forward	550	550	650
Reverse	600	600	700
Working Torque (Ft. - Lbs.)			
Forward	500	500	550
Reverse	550	550	600
Free Speed R.P.M.	7,500	7,500	7,700
Standard Bolt Capacity	5/8"	5/8"	5/8"
Overall Length	8-1/4"	10-1/4"	7-7/8"
Weight (Lbs.)	5.8	6.1	4.5
Avg. Air Consumption (CFM)	4.4	4.4	4.7
Min. Hose Size	3/8"	3/8"	3/8"
Air Inlet NPT	1/4"	1/4"	1/4"
Sound Pressure (dBA)	88	88	97.3
Vibration (M/S²)	2.69	2.69	4.5

• FOR MAXIMUM PERFORMANCE WE RECOMMEND 90 LB PSI AIR PRESSURE



JET Accessories



MAG WHEEL POWER SOCKETS

Mag wheel power sockets are specially designed for use on high end aluminum and chrome plated panels. Please consult our hand tool catalogue for range and specifications.



500 FT - LBS

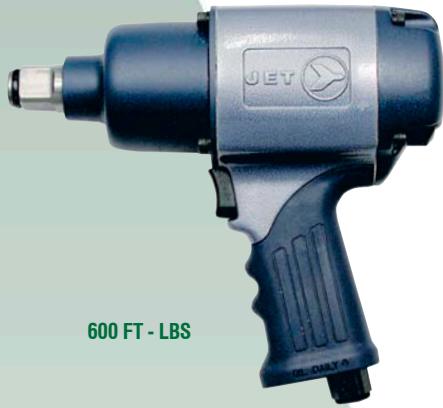

600 FT - LBS



750 FT - LBS

JET Accessories



3/4" and 1" POWER SOCKETS

JET carries a full line of heavy duty 3/4" and 1" drive power sockets and sets. Please consult our hand tool catalogue for range and specifications.

IMPACT WRENCHES

**3/4" DRIVE Standard Duty
YW19CP (400303)**

- Built-in regulator matches speed and power to each job
- Hammer clutch mechanism
- Convenient forward/reverse switch allows quick direction changes
- This economical 3/4" impact wrench offers good performance for automotive, farm maintenance and light industrial uses
- Replacement vinyl cover (Prod. No. 905127)
- **MAXIMUM TORQUE: 500 FT - LBS**

**3/4" DRIVE MAGNESIUM SERIES Heavy Duty
AW19MHD (400312)**

- Same great AW500MSD MAGNESIUM SERIES features in a 3/4" drive
- Unique to JET, a 3/4" drive impact built on our famous 1/2" drive MAGNESIUM SERIES frame
- Our most compact and light weight 3/4" drive impact. Ideal for applications where light weight and high performance is required
- **MAXIMUM TORQUE: Forward 550 FT - LBS, Reverse 600 FT - LBS**

**3/4" DRIVE Heavy Duty
AW19TH (400309)**

- Twin hammer impact mechanism provides more power and smooth, balanced impact blows for reduced vibration
- Forward and reverse valve is equipped with three forward and one reverse, positive throttle settings
- Handle exhaust for maximum operator comfort
- Pistol grip contoured to protect the throttle trigger
- Insulating rubber handle cover for operator comfort and safety
- Steel hammer case offers superior protection
- Three piece construction allows quick easy maintenance
- Anvil features snap ring and pin hole type socket retainer
- Air inlet screen for extended motor life
- Replacement rubber handle cover (Prod. No. 905125)
- **MAXIMUM TORQUE: 750 FT - LBS**

MOD. NO. PROD. NO.	YW19CP 400303	AW19MHD 400312	AW19TH 400309
Square Drive	3/4"	3/4"	3/4"
Max. Torque (Ft. - Lbs.)	—	—	—
Forward	500	550	750
Reverse	—	600	—
Working Torque (Ft. - Lbs.)	—	—	—
Forward	120 - 300	500	35 - 600
Reverse	—	550	—
Free Speed R.P.M.	5,000	7,500	6,500
Standard Bolt Capacity	3/4"	5/8"	7/8"
Overall Length	10"	8-1/4"	9"
Weight (Lbs.)	10.1	5.9	9.7
Avg. Air Consumption (CFM)	7.5	4.4	7
Min. Hose Size	3/8"	3/8"	3/8"
Air Inlet NPT	1/4"	1/4"	1/4"
Sound Pressure (dBA)	—	88	86
Vibration (M/S²)	—	2.69	1.5

• FOR MAXIMUM PERFORMANCE WE RECOMMEND 90 LB PSI AIR PRESSURE

IMPACT WRENCHES



3/4" DRIVE MAGNESIUM SERIES Super Duty AW19MSD (400313)

- Twin hammer impact mechanism provides more power and smooth, balanced impact blows for reduced vibration
- Super strong magnesium housing - lighter and stronger than aluminum, magnesium absorbs impact vibration better than other materials, improving operator comfort and reducing fatigue
- Exceptionally well balanced tool, for comfort and ease of handling
- Ergonomic handle shaped to fit the operator's hand features: finger grooves for comfort and control; insulating and shock absorbing rubber cover extends to upper rear of handle to protect the web of the hand
- Exhaust air outlet features an effective muffler system for reduced noise in the work area
- Handle exhaust directs air away from the operator and the work piece
- Forward/Reverse control positioned for ease of use, three forward and one reverse setting
- Maximum power in reverse for removing those stubborn fasteners
- Specially treated anvil for extra long service life
- A professional tool for professional users. Ideal for all automotive, industrial and farm service applications including truck, shock, frame, engine & spring work
- **MAXIMUM TORQUE: Forward 1,100 FT - LBS, Reverse 1,200 FT - LBS**



1,200 FT - LBS

3/4" DRIVE MAGNESIUM SERIES Super Duty (6" Extended Anvil) AW19MSD6 (400314)

- Same great MAGNESIUM SERIES features in a 6" extended anvil version
- **MAXIMUM TORQUE: Forward 1,100 FT - LBS, Reverse 1,200 FT - LBS**



NEW!

1,200 FT - LBS

3/4" DRIVE COMPOSITE SERIES Super Duty AW19CSD (400317)

- Super strong and super light weight, featuring the latest in composite technology, AW19CSD delivers an awesome 1,200 FT/LBS of nut wrenching power in an incredibly light 6.9 LB package
- Twin hammer impact mechanism provides more power and smooth, balanced impact blows for reduced vibration
- Unique "Up-Hill Soft-Grip" design makes this tool ideal for long hours on the job
- Muffled, handle mounted air outlet adds to operator comfort and safety
- "Dial type" Forward/Reverse control positioned for ease of use, three forward and two reverse setting
- Maximum power in reverse for removing those stubborn fasteners
- Specially treated anvil for long service life
- A professional tool for professional users. Ideal for all automotive, industrial & farm service applications including truck, shock, frame & spring work
- **MAXIMUM TORQUE: Forward 1,100 FT - LBS, Reverse 1,200 FT - LBS**



NEW!

1,200 FT - LBS

**SUPER STRONG
SUPER LIGHT** COMPOSITE HOUSING



MOD. NO. PROD. NO.	AW19MSD 400313	AW19MSD6 400314	AW19CSD 400317
Square Drive	3/4"	3/4"	3/4"
Max. Torque (Ft. - Lbs.)			
Forward	1,100	1,100	1,100
Reverse	1,200	1,200	1,200
Working Torque (Ft. - Lbs.)			
Forward	800	800	800
Reverse	880	880	880
Free Speed R.P.M.	5,500	5,500	5,750
Standard Bolt Capacity	1-1/4"	1-1/4"	1-1/4"
Overall Length	8-3/4"	15"	8-1/2"
Weight (Lbs.)	11.3	13.27	6.9
Avg. Air Consumption (CFM)	9.5	9.5	6.9
Min. Hose Size	1/2"	1/2"	3/8"
Air Inlet NPT	3/8"	3/8"	3/8"
Sound Pressure (dBA)	87	87	89.6
Vibration (M/S²)	3.59	3.59	1.71

• FOR MAXIMUM PERFORMANCE WE RECOMMEND 90 LB PSI AIR PRESSURE

905-814-6859 - 1-866-517-3289 - www.marcur.com

JET Accessories



3/4" and 1" POWER SOCKETS

JET carries a full line of heavy duty 3/4" and 1" drive power sockets and sets. Please consult our hand tool catalogue for range and specifications.



1,700 FT - LBS

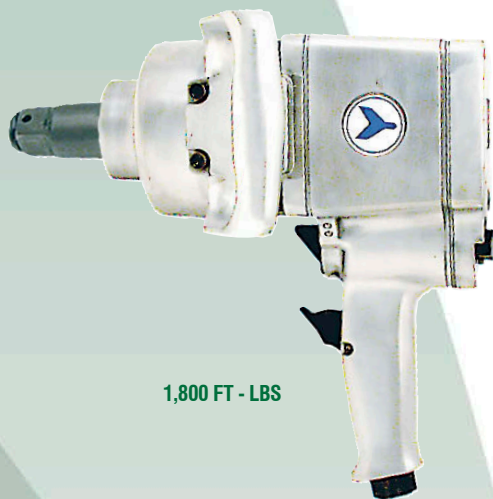

1,800 FT - LBS

IMPACT WRENCHES

1" DRIVE PISTOL GRIP Heavy Duty AW381PA (400433)

- Compact pistol grip design permits the use of maximum power in tight places
- Forward and reverse valve is equipped with six positive throttle settings
- Air inlet screen for extended motor life
- Exhaust deflector directs exhaust air away from the operator
- Pistol grip contoured to protect the throttle trigger and provide operator comfort and control
- Anvil features snap ring and pin hole type socket retainer
- Pin hammer construction for improved durability
- Top Mounted D-handle contoured for comfort and control
- **MAXIMUM TORQUE: 1,700 FT - LBS**

1" DRIVE PISTOL GRIP Super Duty AW38PSD (400434)

- Twin hammer impact mechanism provides more power and smooth, balanced impact blows for reduced vibration
- Compact pistol grip design permits the use of maximum power in tight places
- Forward and reverse valve is equipped with four positive throttle settings
- Adjustable exhaust deflector for maximum operator safety and comfort
- Three piece construction allows quick easy maintenance
- Side mounted D-handle is angled for balance and combined with the extra long pistol grip provides the best possible control
- Anvil features pin hole and spring clip type socket retainer
- Air inlet screen for extended motor life
- **Capable of operating at 150 to 170 LB PSI air pressure.**
Ideal for use on high pressure air systems
- **MAXIMUM TORQUE: 1,800 FT - LBS**

JET Accessories



1" DRIVE POWER SOCKETS

1" drive power sockets now featuring expanded sizes up to 3 1/2". Features complete range of 1" drive sockets made from premium grade chrome molybdenum steel. Please consult our hand tool catalogue for range and specifications.

MOD. NO.	AW381PA	AW38PSD
PROD. NO.	400433	400434
Square Drive	1"	1"
Max. Torque (Ft. - Lbs.)	1,700	1,800
Working Torque (Ft. - Lbs.)	250 - 1,280	100 - 1,200
Free Speed R.P.M.	5,300	4,000
Standard Bolt Capacity	1-1/2"	1-1/4"
Overall Length	10-1/2"	11-1/2"
Weight (Lbs.)	21	24.4
Avg. Air Consumption (CFM)	10	9
Min. Hose Size	1/2"	1/2"
Air Inlet NPT	1/2"	1/2"
Sound Pressure (dBA)	—	86
Vibration (M/S ²)	—	0.6

- **FOR MAXIMUM PERFORMANCE WE RECOMMEND 90 LB PSI AIR PRESSURE**
- **AW38PSD - FOR MAXIMUM PERFORMANCE WE RECOMMEND 90-120 LB PSI AIR PRESSURE**

IMPACT WRENCHES



1" DRIVE D-HANDLE Super Duty (2" Anvil) AW38SD2 (400437)

- Twin hammer impact mechanism provides more power and smooth, balanced impact blows for reduced vibration
- D-handle design complete with side handle for maximum operator control
- Forward and reverse valve is equipped with three positive throttle settings
- Exhaust outlet directs exhausted air away from the operator for maximum safety and comfort
- Three piece construction allows quick easy maintenance
- Internally mounted throttle trigger for operator safety and convenience
- Anvil features pin hole and spring clip type socket retainer
- Air inlet screen for extended motor life
- **Capable of operating at 150 to 170 LB PSI air pressure.**
Ideal for use on high pressure air systems
- **MAXIMUM TORQUE: 1,800 FT - LBS**



1,800 FT - LBS

1" DRIVE D-HANDLE Super Duty (6" Anvil) AW38SD6 (400442)

- Twin hammer impact mechanism provides more power and smooth, balanced impact blows for reduced vibration
- 6" extended anvil to access lug nuts in deep truck wheels
- D-handle design complete with side handle for maximum operator control
- Forward & reverse valve is equipped with three positive throttle settings
- Exhaust outlet directs exhausted air away from the operator for maximum safety and comfort
- Three piece construction allows quick easy maintenance
- Internally mounted throttle trigger for operator safety & convenience
- Anvil features pin hole and spring clip type socket retainer
- Air inlet screen for extended motor life
- **Capable of operating at 150 to 170 LB PSI air pressure.**
Ideal for use on high pressure air systems
- **MAXIMUM TORQUE: 1,800 FT - LBS**



1,800 FT - LBS

#5 SPLINE DRIVE D-HANDLE Super Duty (6" Anvil) AW38SD6S (400447)

- Twin hammer impact mechanism provides more power and smooth, balanced impact blows for reduced vibration
- Features #5 spline drive anvil for positive socket connection
- 6" extended anvil to access lug nuts in deep truck wheels
- D-handle design complete with side handle for maximum operator control
- Forward and reverse valve is equipped with three positive throttle settings
- Exhaust outlet directs exhausted air away from the operator for maximum safety and comfort
- Three piece construction allows quick easy maintenance
- Internally mounted throttle trigger for operator safety & convenience
- Air inlet screen for extended motor life
- **Capable of operating at 150 to 170 LB PSI air pressure.**
Ideal for use on high pressure air systems
- **MAXIMUM TORQUE: 1,800 FT - LBS**



1,800 FT - LBS

MOD. NO. PROD. NO.	AW38SD2 400437	AW38SD6 400442	AW38SD6S 400447
Drive	1"	1"	#5 Spline
Max. Torque (Ft. - Lbs.)	1,800	1,800	1,800
Working Torque (Ft. - Lbs.)	100 - 1,200	100 - 1,200	100 - 1,200
Free Speed R.P.M.	4,000	4,000	4,000
Standard Bolt Capacity	1-1/4"	1-1/4"	1-1/4"
Overall Length	15"	21-1/2"	21-1/2"
Weight (Lbs.)	23	27	27
Avg. Air Consumption (CFM)	9	9	9
Min. Hose Size	3/4"	3/4"	3/4"
Air Inlet NPT	1/2"	1/2"	1/2"
Sound Pressure (dBA)	88	88	88
Vibration (M/S ²)	0.6	0.6	0.6

• FOR MAXIMUM PERFORMANCE WE RECOMMEND 90 - 120 LB PSI AIR PRESSURE

JET Accessories

NEW!



TRUCK TIRE POWER SOCKETS

JET truck tire power sockets are designed for use on most truck wheel fasteners. Please consult our hand tool catalogue for range and specifications.